

XCT-B 400w

Top class high performance and unique, extremely compact TIG torch design



The XCT-B 400w has pioneering technology inside and is dedicated to professional end-users looking for a high performing torch, with extraordinary small torch neck-to-head dimensions providing the ability to weld in the tightest spaces with maximum precision. The ball joint allows free movement in all directions without torsion of the cable assembly.

The compact size of XCT-B 400w and high performance power rating makes this torch a perfect tool for hand-held TIG welding.

The unique XCT collet replaces the conventional parts and stays constantly reliable even under high load. The collet creates a large area of contact between the electrode and water-cooled torch head. This ensures an exceptionally efficient transfer of current and heat.

- Torch head and XCT collet have been carefully optimised. The torch achieves gas shielding that is comparable with using a gas lens
- Simplified system with only three extremely durable wear parts
- Equipped with the new Precision Switch technology allowing for precise operation with optimised ergonomics
- Extensively tested and a proven, compact design with high durability
- Extremely compact head size

Visit esab.com for more information.

Industry

- Aerospace
- Automotive
- Food and Beverage
- Light Fabrication
- Marine and Offshore
- Petrochemical
- Pipeline
- Steel Industry
- Tank and Vessel Fabrication

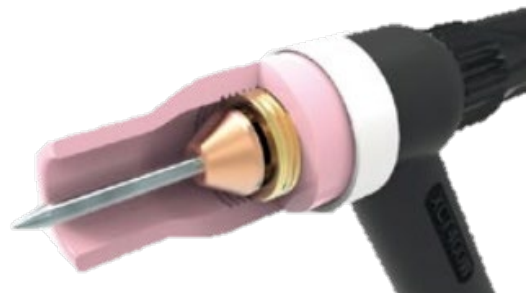

The unique XCT consumables secure a firm grip of the electrode and optimal current transfer. The design of the torch head further secures perfect gas coverage, which eliminates the need for gas lenses.

XCT-B 400w

Specifications

Welding Output AC / DC 100% Duty Cycle	315 A AC / 450 A DC
Electrode Ø	1.6 - 4.0 mm
Cable Length	4 m, 8 m, 12 m, 16 m
Cooling	Water

Ordering Information

Torch	Cooling	OKC 50, 2-Pin Amphenol Plug			
		4 m	8 m	12 m	16 m
XCT-B 400w	Water	0700025540	0700025541	0700025542	0700025543

Wear & Spare Parts

No.	Description	Part Number
1	Back Cap, Long	0700025650
	Back Cap, Medium	0700025651
	Back Cap, Short	0700025652
2	Heat Shield	0700025653
3	Collet	0700025654 (Ø 1.6)
		0700025655 (Ø 2.4)
		0700025656 (Ø 3.2)
		0700025657 (Ø 4.0)
4	Gas Nozzle L = 25.5 mm	0157121032 (Ø 6.4, No. 4)
		0157121033 (Ø 8.0, No. 5)
		0157121034 (Ø 9.8, No. 6)
		0157121039 (Ø 11.2, No. 7)
		0157121040 (Ø 12.7, No. 8)
		0700025698 (Ø 16.0, No. 10)
5	Gas Nozzle L = 35.0 mm	0700025658 (Ø 6.4, No. 4)
		0700025659 (Ø 8.0, No. 5)
		0700025660 (Ø 9.8, No. 6)
		0700025661 (Ø 11.2, No. 7)
		0700025699 (Ø 16.0, No. 10)

Bold = standard delivery

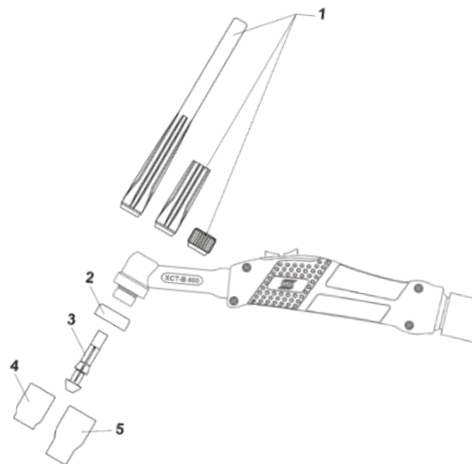

ESAB / esab.com

